

# LPS AUTOMATIC LOADING SYSTEMS

## NS-AUTOMATIC LOADER FOR FRAGILE AND SOFT PRODUCTS

- Sanitary design for easy cleaning
- CE compliant
- Handles a wide range of product sizes
- Capable of loading 2,3,4 rows configurations
- Servo driven system provides multiple packaging options

- Up to 2.000 pieces per minute
- Diameter range: 15 to 33 mm
- Length range: 80 to 230 mm
- Handles product with or without casing
- Touch screen control
- Modular interchangeable loading head
- Compact footprint

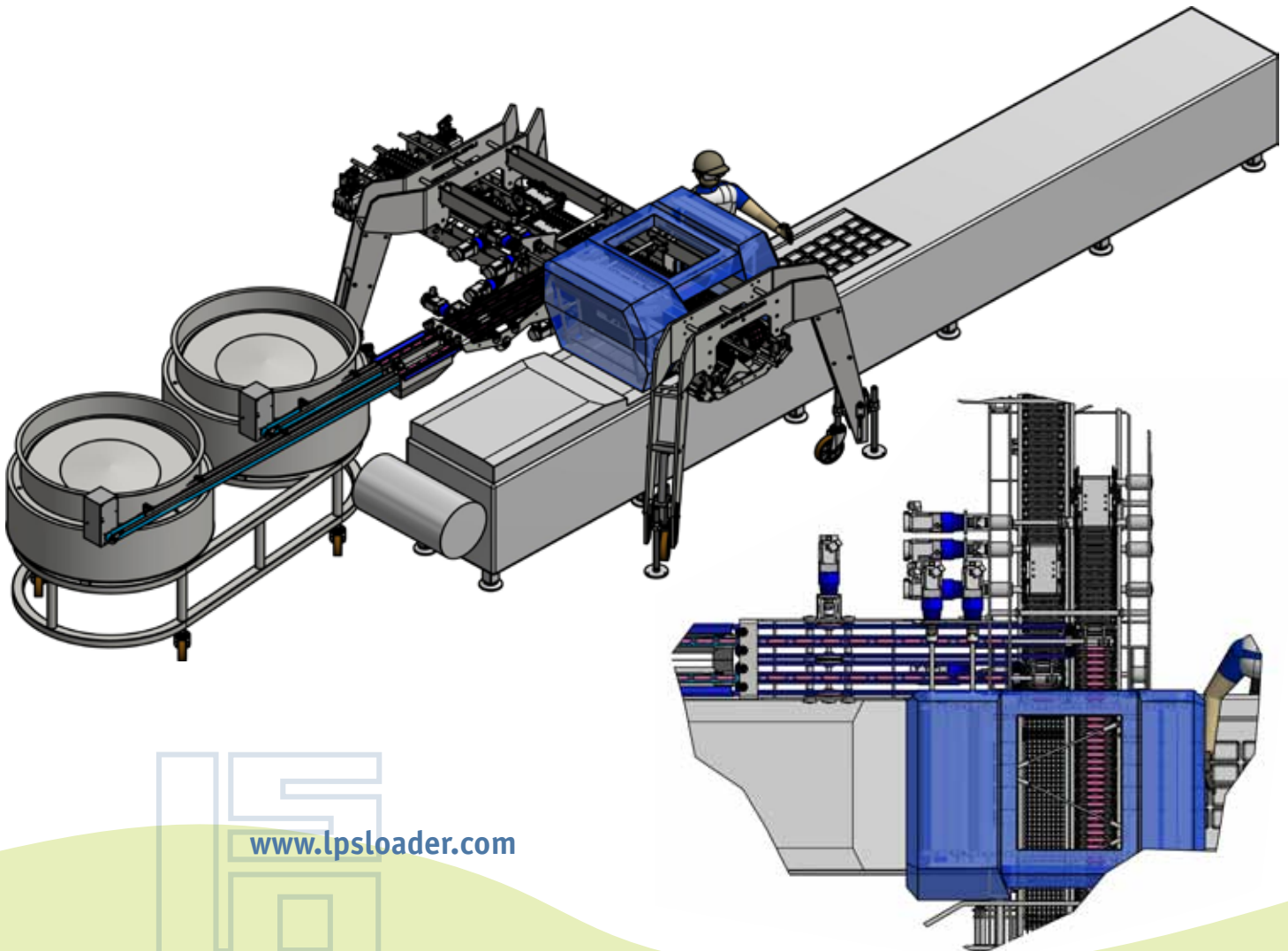

[www.lpsloader.com](http://www.lpsloader.com)



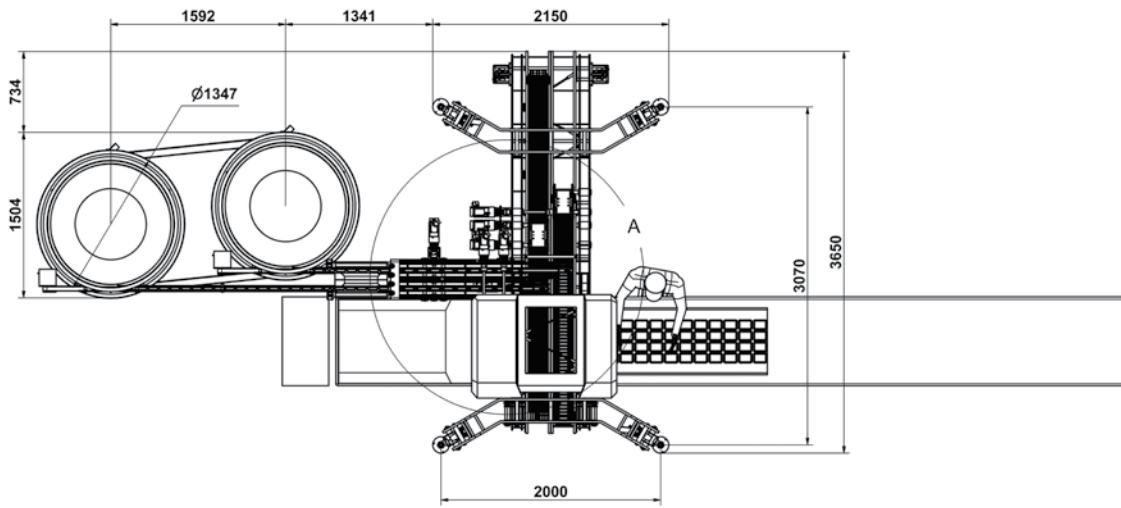

## SPECIFICATIONS

- Product dimensions:  
15 to 33 mm diameter  
(may require the change of shuttle conveyor), 80 to 230 mm length,  
other sizes available upon request .
- Package arrangements:  
From one to thirty four packages per cycle,  
single or multiple layers.
- Set up time: 10 to 15 minutes
- Operator/Inspector: 1



## PACKAGING CONFIGURATIONS

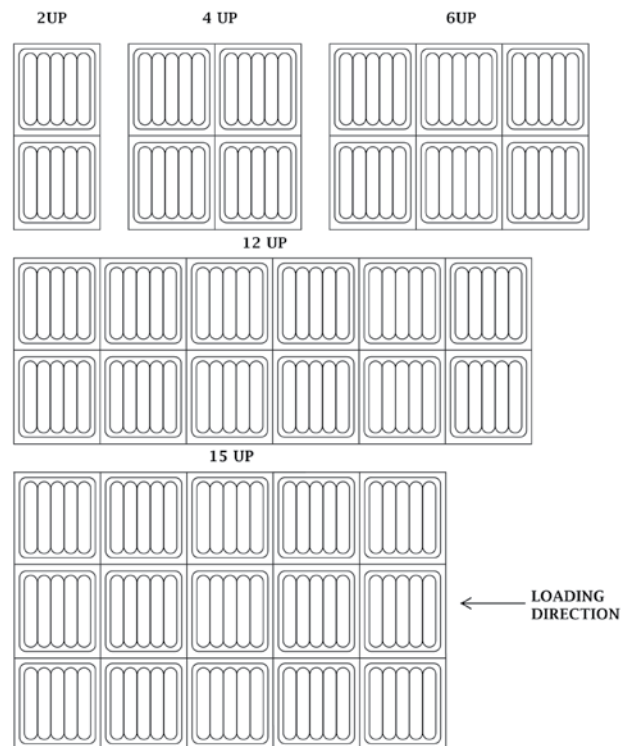

[www.lpsloader.com](http://www.lpsloader.com)

L.P.S. srl

Via Trento, 66/B - 20871 Vimercate (MB)  
ITALY +39 039 6084343 - info@lpsrsl.com